

# BEST 105

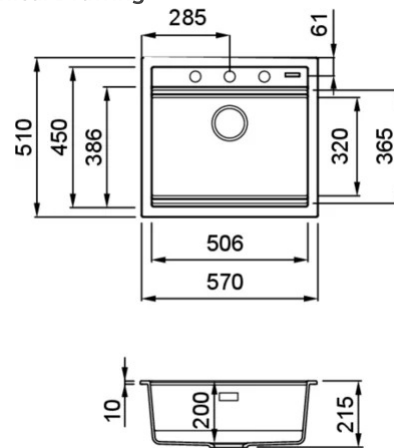

## Technical Drawing



0

<b>Description</b>	1-bowl sink
<b>Model</b>	BEST 105
<b>Base (mm)</b>	600
0	Inset
<b>Dimensions (mm)</b>	570 x 510
<b>Hole for built-in installation (mm)</b>	550 x 480
<b>Number of Bowls</b>	1
<b>Bowl Depth (mm)</b>	200



0

<b>Gross Weight (kg)</b>	13,60
<b>Net Weight (kg)</b>	10,00
<b>Packaging Dimension (kg)</b>	690 x 575 x 300
0 (kg)	0,119

0

<b>Packaging</b>	Cardboard and polyethylene
0	Space-saving siphon, integrated Flow Pro, rectangular overflow and hooks.



**LKB10586 K86**  
8032557029427



**LKB10593 K93**  
8032861020462



**LKB10595 K95**  
8032861020516



**LKB10596 K96**  
8032861020479



**LKB10597 K97**  
8032861020523



**LKB10599 K99**  
8032861020530

**GRANITEK**<sup>®</sup>  
NATURAL GRANITE EFFECT

METAL



**LMB10573** M73  
8031873119249



**LMB10579** M79  
8031873119256

**GRANITEK**<sup>®</sup>  
NATURAL GRANITE EFFECT

MATT



**LGB10578** G78  
8032557066866



**LGB10540** G40  
8032557064930



**LGB10543** G43  
8032557064947



**LGB10548** G48  
8032557064954



**LGB10568** G68  
8032557064961

**GRANITEK**<sup>®</sup>  
NATURAL GRANITE EFFECT

CLASSIC



**LGB10551** G51  
8032557065005



**LGB10559** G59  
8032557065012



**LGB10562** G62  
8032557065029

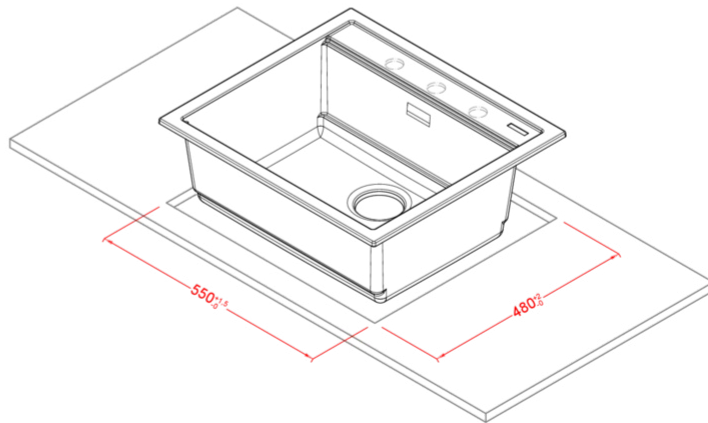
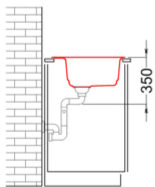
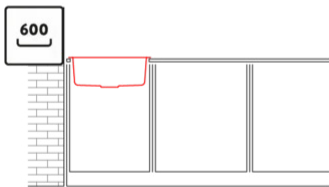
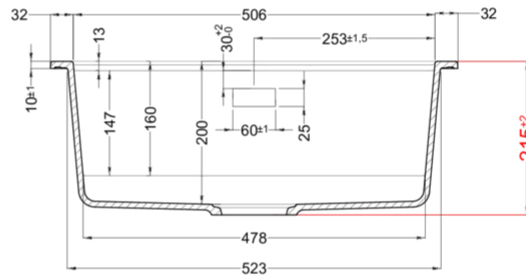
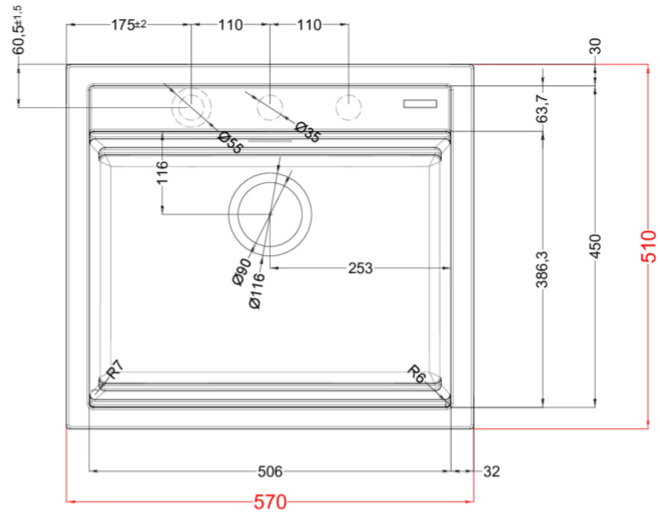
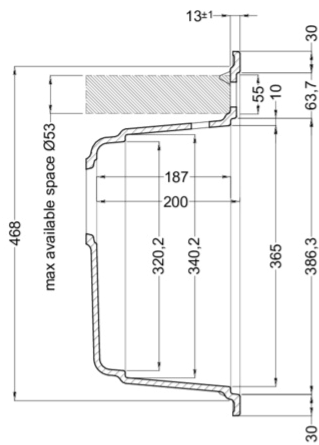

## BEST 105

general tolerances where not expressly communicated  $\pm 0.2\%$   
connection dimensions according to UNI EN 695